

Steps to Prepare Low Loader for Loading a Vehicle

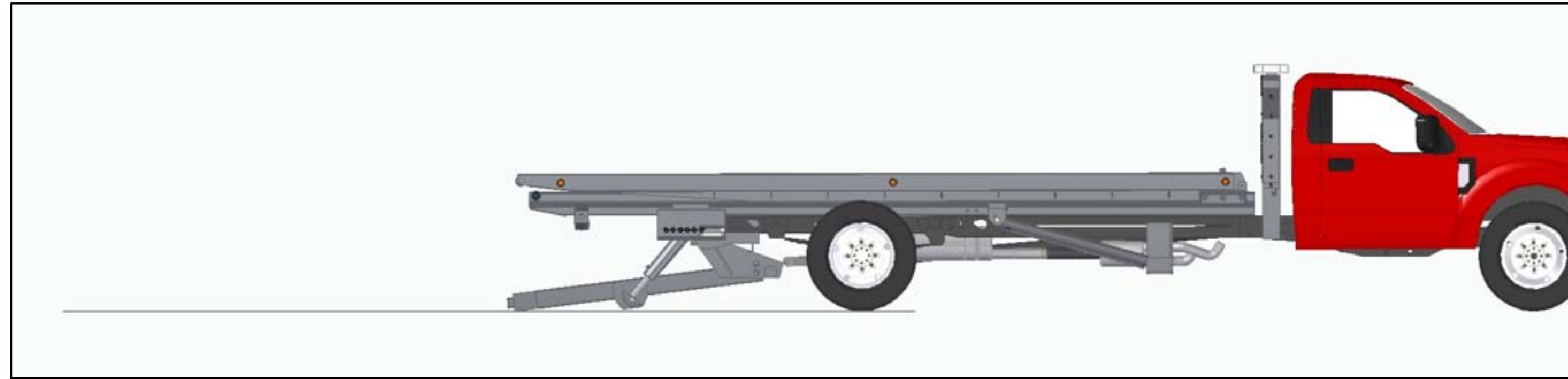

Step 1: If equipped with air bag suspension, dump the air bags. Then lower the Wheel Lift until it touches the ground.

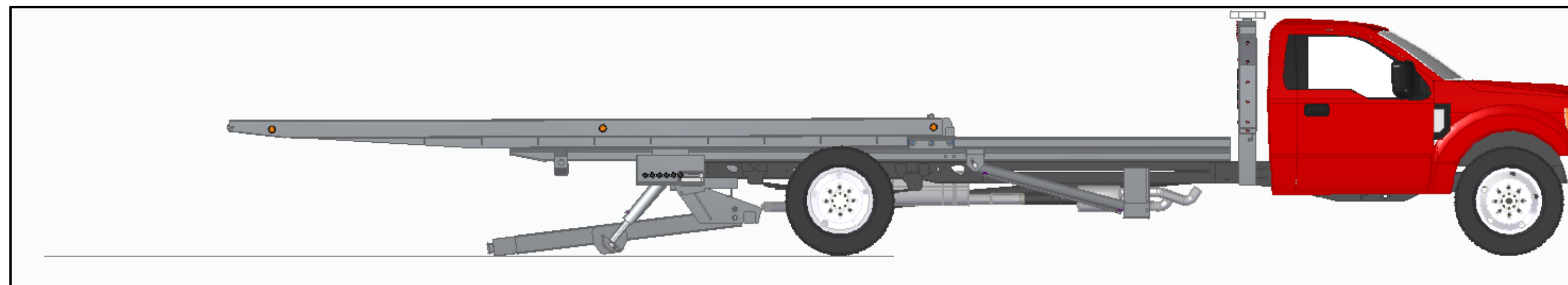

Step 2: Slide the Bed back about half way

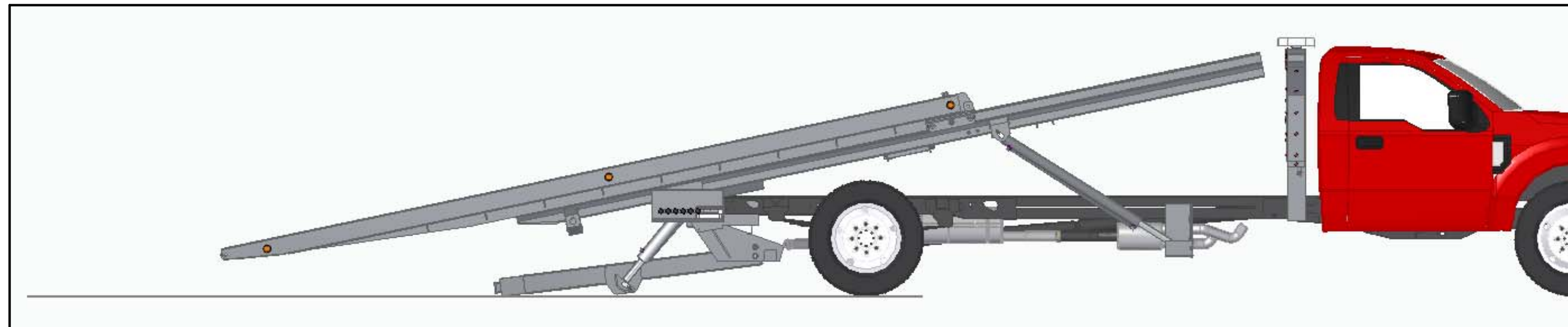

Step 3: Tilt the Subframe up so it's as high as the cab of the truck, but not higher.

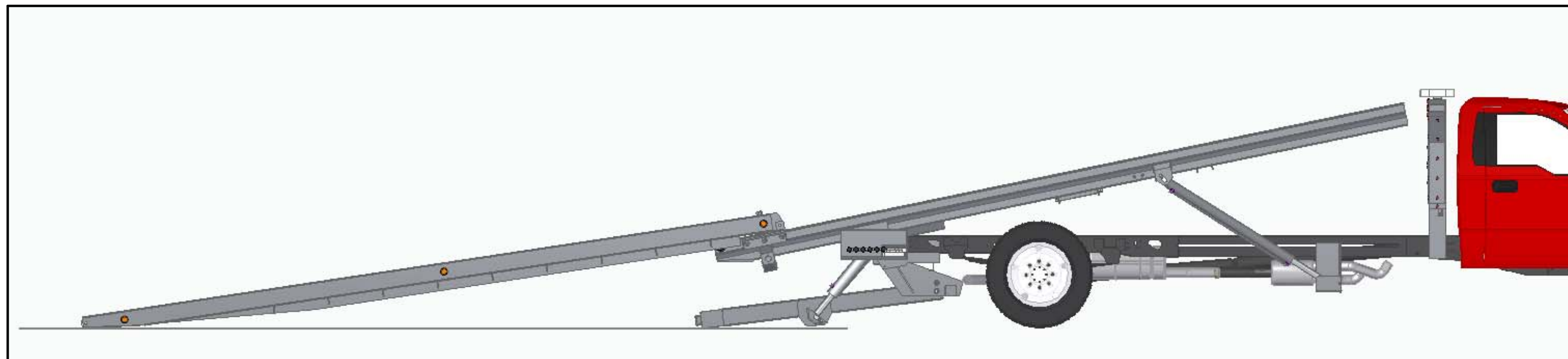

Step 4: Slide the Bed back all the way

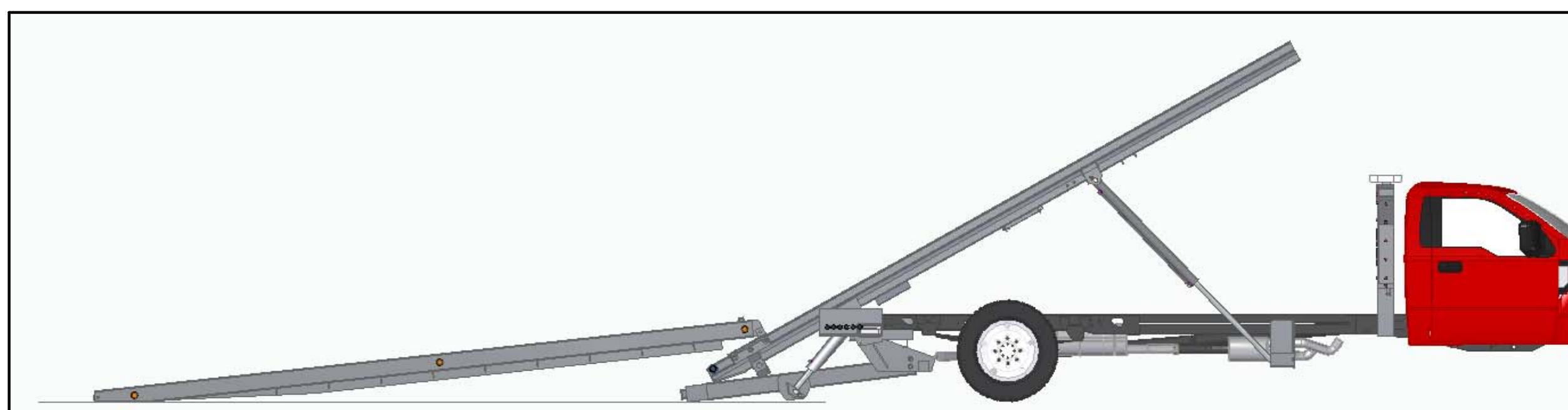

Step 5: Tilt the Subframe up more until the Bed reaches the desired loading angle



Steps to Load a Vehicle onto the Low Loader

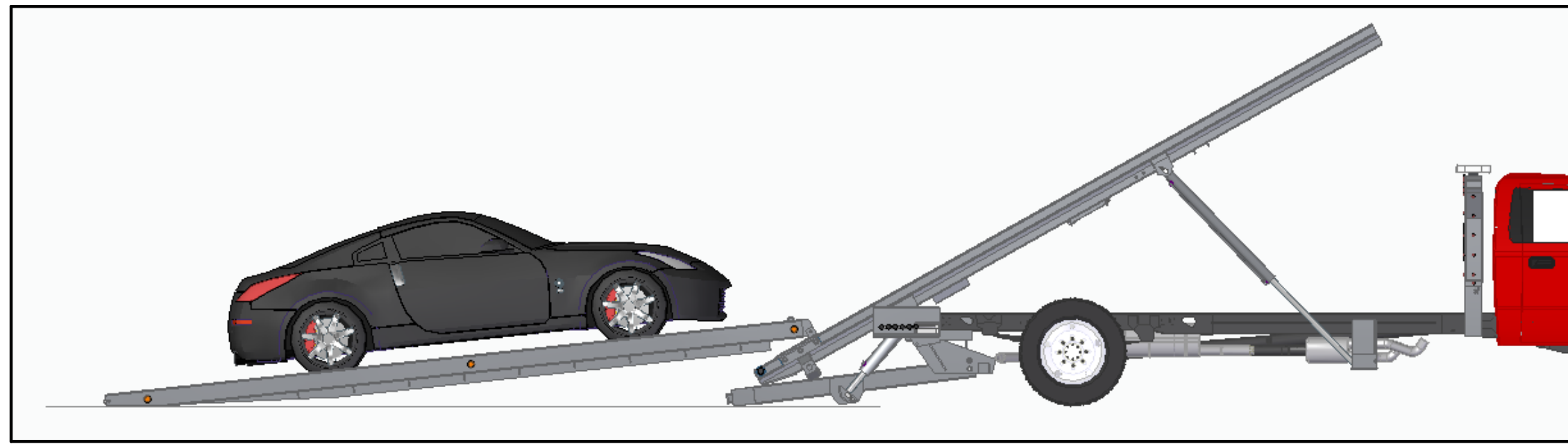

Step 6: Load vehicle onto Bed and secure the vehicle to the Bed.

Secure the vehicle to the bed at all four corners.
(The Winch does not count as an attachment point)

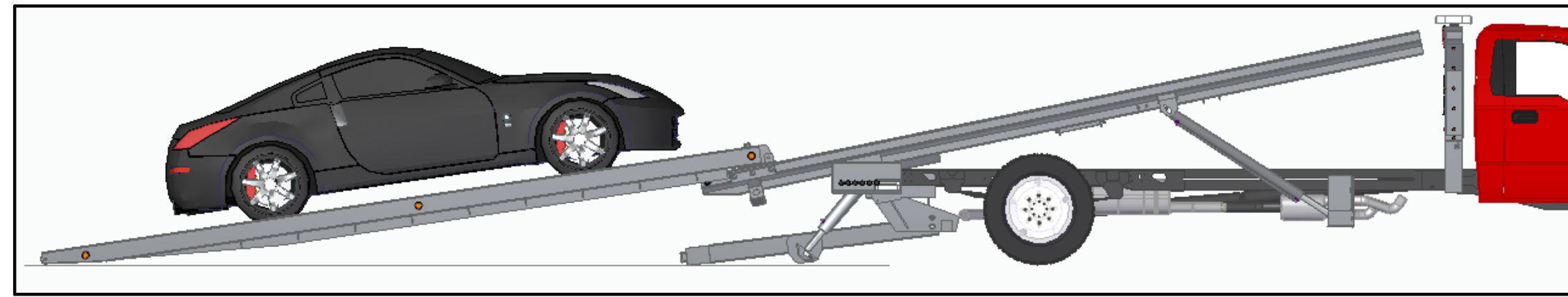

Step 7: Lower Subframe until it is lined up with top of cab

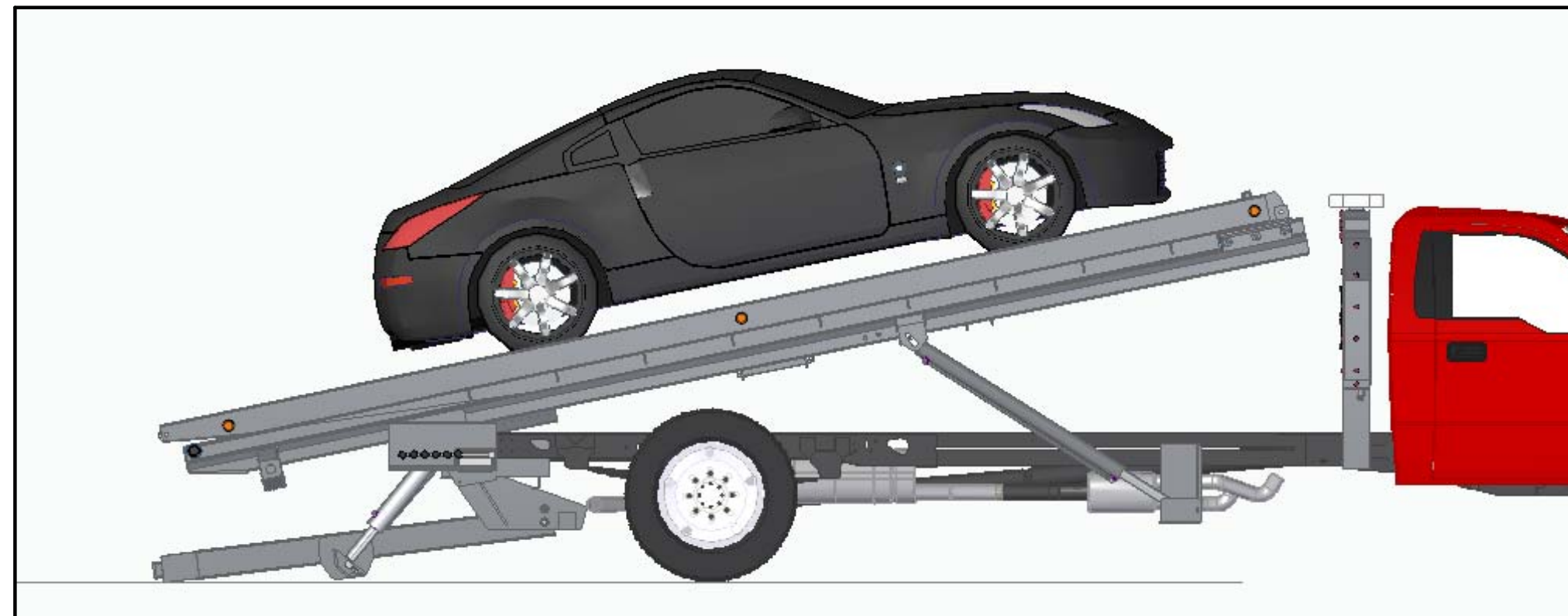

Step 8: Slide the Bed all the way forward

WARNING: Tilting the load before it's between the axles will cause damage.
DO NOT TILT THE BED DOWN UNLESS THE LOAD IS FORWARD OF THE REAR AXLE.

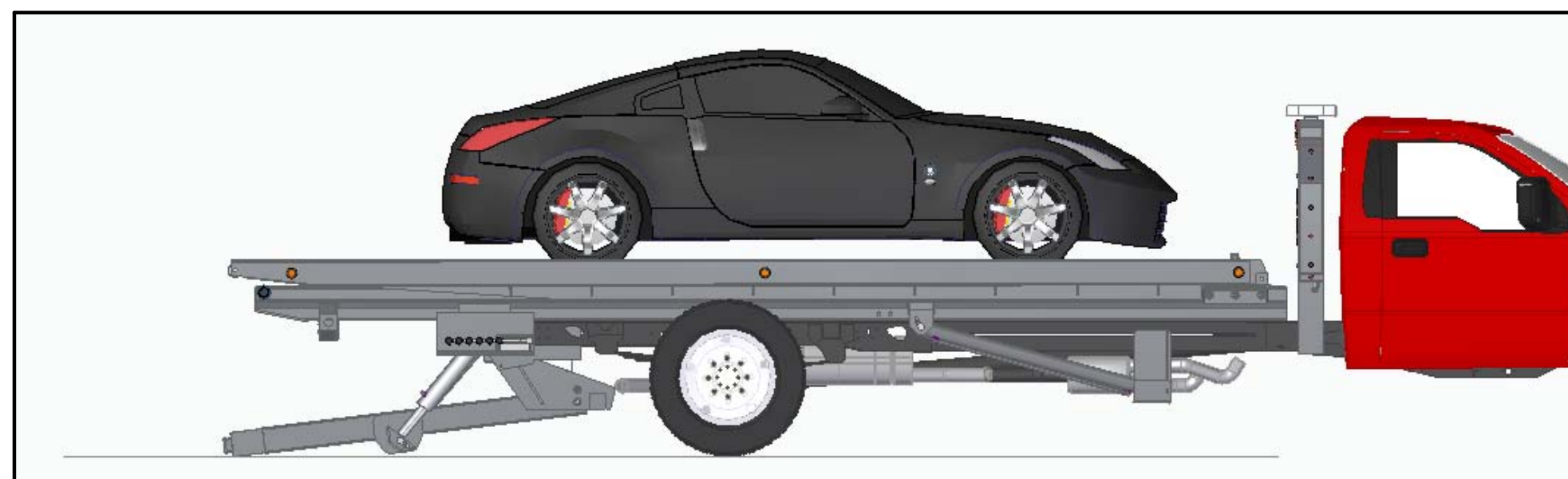

Step 9: Gently lower the Subframe all the way down

Step 10: Slide the Bed back to the stowed position, if not already back all the way

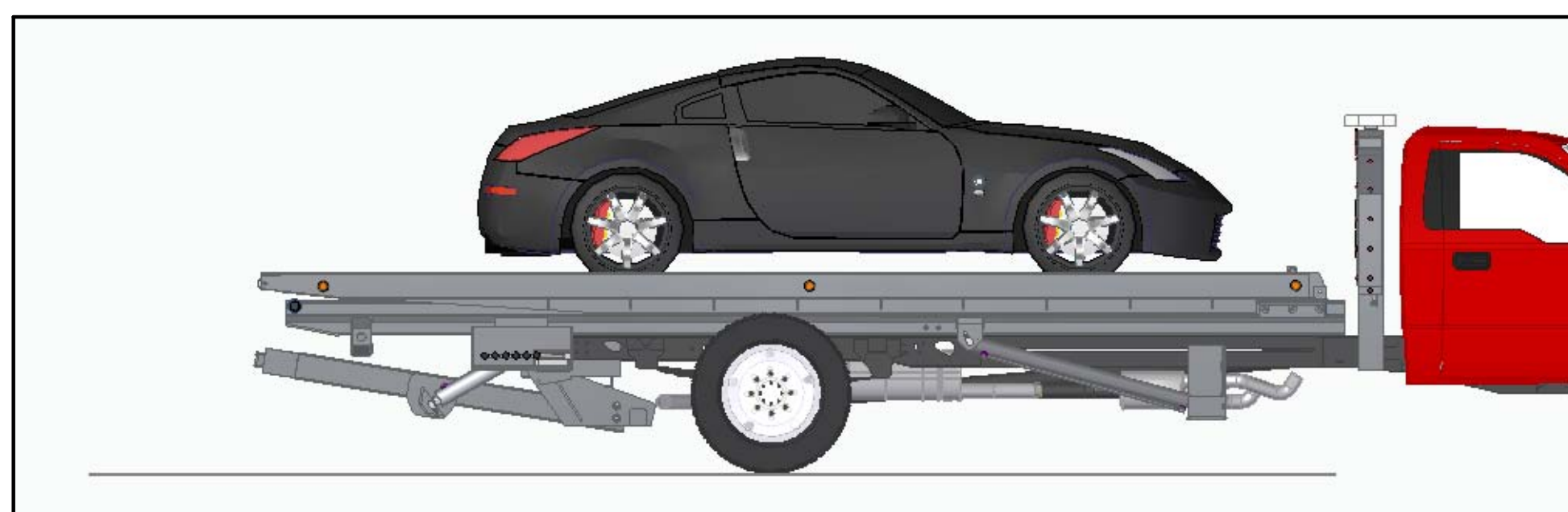

Step 11: Raise the Wheel Lift back to stowed position. Then fill the air bag suspension back up, if equipped.

DONE

